

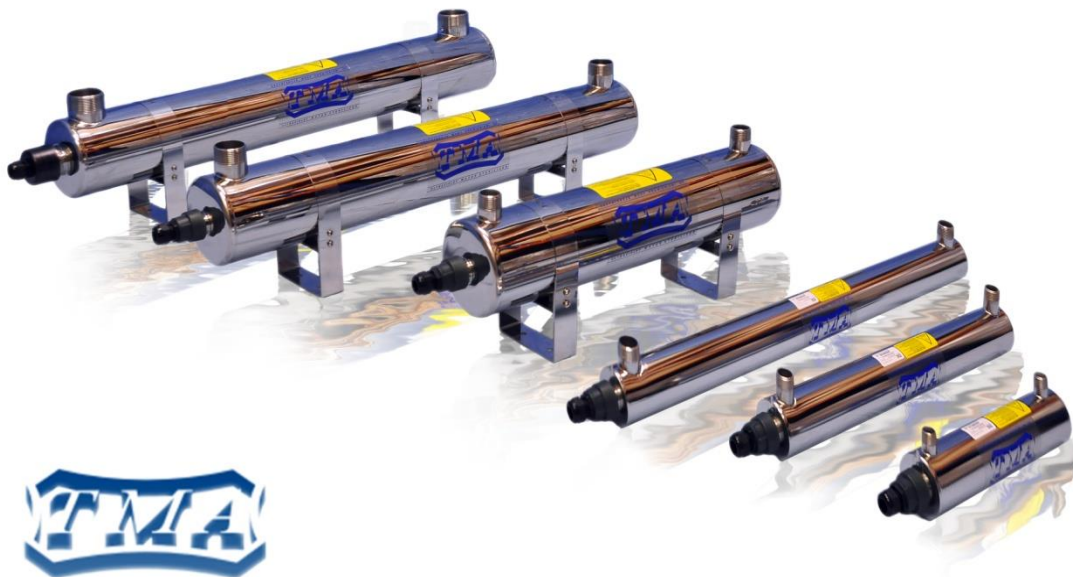

Manufactured in Poland

**WATER STERILIZERS
D SERIES**

MODELS: D2; D4; D6; D6-S; D8; D8-S;
D10; D12; D14



MANUAL

Patent no. 204935

TABLE OF CONTENTS:

1.	GENERAL INFORMATION	4
2.	APPLICATIONS.....	5
3.	TECHNICAL DESCRIPTION	5
4.	TECHNICAL SPECIFICATION.....	6
5.	INSTRUCTIONS FOR INSTALLATION AND OPERATION	8
5.1.	CORRECT ASSEMBLY OF THE CHAMBER	8
5.2.	CORRECT ASSEMBLY OF THE ELECTRICAL ENCLOSURE	9
6.	CONNECTION OF SOLENOID VALVE OR LEADING THE ALARM SIGNAL OUT IN D6-S, D8-S, , D12, D14	10
6.1.	CONNECTION OF SOLENOID VALVE	11
6.2.	LEADING OUT THE ALARM SIGNAL	11
6.3.	REMOTE-CONTROLLED ON/OFF SWITCH	11
7.	MAINTENANCE.....	11
8.	DESCRIPTION OF INDICATORS IN ELECTRICAL ENCLOSURES.....	12
8.1.	IN D2, D4, D6, D8, D10	12
8.2.	IN D6-S, D8-S, D12, D14.....	13
9.	D SERIES STERILIZERS SERVICE.....	14
9.1.	REPLACEMENT OF UV LAMP	14
9.2.	RESETTING THE COUNTER IN THE ALARM SYSTEM / IN D6-S, D8-S, D12, D14/.....	14
9.3.	REPLACEMENT AND CLEANING OF THE QUARTZ SLEEVE /FRAGILE AND BRITTLE/.....	15
9.4.	TROUBLESHOOTING.....	15
10.	SPARE PARTS LIST.....	16
11.	GRAPHIC ASSEMBLY INSTRUCTIONS	16
11.1.	ASSEMBLY OF THE STERILIZERS WITH BRACKETS – D6, D6-S, D10, D12, D14.....	17
11.2.	ASSEMBLY OF THE ELECTRICAL ENCLOSURES IN D6-S, D8-S, D12, D14.....	18
11.3.	ASSEMBLY OF D2, D4, D8, D8-S	19
11.4.	ASSEMBLY OF D6, D6-S, D10, D12, D14	20
12.	DECLARATION OF CONFORMITY.....	21
13.	HYGIENIC CERTIFICATE	22
14.	SHIPPING.....	23
15.	WARRANTY	23

USER SAFETY

WARNING!!!

This device may only be operated and installed by qualified personnel. Before installation, servicing or repairs verify the qualifications and limit these activities to such personnel. Any activities on this device can only proceed after thorough familiarization with this instruction. Noncompliance with the precautions listed hereon might expose the personnel to serious bodily harm (damage to human skin from UV radiation), or damage to the device alone. The manufacturer, TMA, is not responsible for damage to the device caused by improper installation, maintenance and operation.



READ THE MANUAL

Before proceeding with any activity with the sterilizers read the manual. Familiarize the personnel with the manual and safety instructions. Retain the manual for reference during the whole time the device is in operation. All precautions and warnings shall be obeyed by the user at all times during the operation of the device.

UV RADIATION

TMA UV Sterilizers use lamps that emit UVC radiation. The design of the sterilizers ensures the safety of the user. Direct exposure to UV radiation is harmful to human skin and sight. As a result of direct UV radiation, reddening of skin, serious burns or ultimately loss of eyesight may occur (depending on the time of exposure). In such cases one shall contact a physician as soon as possible. Direct exposure to UVC radiation should be strictly avoided. UVC radiation used for disinfection cannot be used for medicinal or cosmetic purposes.

POWER SUPPLY

The device is exclusively designed to be supplied from 220-230V 50Hz mains. It shall be installed and grounded in accordance with this manual and the local electrical code. To guard against electrical shock, unplug the device every time work is to be done on it.

GROUNDING

Operation of the device without connected grounding is inadmissible! Ungrounded operation might lead to occurrence of electrical shock and serious bodily harm with death included.

OPERATION SAFETY/SERVICE

The use of original parts provided by TMA ensures appropriate safety and UV disinfection efficacy conditions. All maintenance activities on this device can only be performed by qualified personnel. Noncompliance with the safety precautions as well as inadequate use of the device may result in body and eyesight damage.



The used electrical and electronic equipment with the crossed-out rubbish bin symbol shall be collected separately. It is prohibited to put the used equipment with other waste. Inadequate use of the used equipment may have a negative impact on the environment and people's health. Separate collection of the equipment contributes to its re-use and recycling. The obligation of the used equipment selective collection rests on the user, who should provide it to the used equipment collector. TMA devices are equipped with lamps that emit UV radiation, light sources that contain mercury. The owners of waste lamps containing mercury are obliged to collect them separately for further re-use and disposal.

1. General information

Thank you for your purchase of TMA manufactured UV sterilization product. All the raw materials and components are of best quality and were processed or manufactured in the EU countries. Sterilizers made by TMA are made from highest quality stainless steel. The thickness of the chamber wall guarantees high factor of safety in operation. All of the devices successfully completed 30 Atm pressure trials.

The innovative design of the TMA sterilizers allows for continuous work of the devices even without the flow of water through the chamber. The design of the chamber contributes to lower incidence of sediment from calcium and magnesium on the surface of the quartz sleeve.

In the sterilizers of the D series we introduced additional guides for the quartz sleeves easing the assembly and disassembly. The solution allows for the same ease of assembly for device working horizontally, vertically or at any other angle. The guide prevents the quartz sleeve from breaking during routine maintenance. The turbulent flow induced by the guide increases the efficiency of disinfection. During the first 100 hours of operation the efficiency of disinfection is greater by 15% from the rated for the device.

We provide you with devices equipped with a new electronic control panel (in D6-S, D8-S, D12, D14) that indicates:

- Total work time (days),
- Remaining time until UV lamp replacement (days),
- Number of ON/OFF cycles,
- Visual and audible signal 7 days before the required UV lamp replacement,
- Visual and audible signal when UV lamp replacement is required,
- Visual and audible signal when UV lamp is burnt out.

The detailed instructions of the new panel are provided on the casing of the electrical enclosure.

Sterilizers of the D series have a steel muff with a hood that functions as a sight glass. This innovative solution of a light muff allows for optical control of the working condition of the lamp.

We hold high hopes that the implementations of these innovative solutions in the D series sterilizers fulfill your expectations concerning the effectiveness and operation of our devices.

The device delivered to you shall be protected from severe shocks and drops, as the quartz sleeve and UV lamps are brittle and fragile. The sterilizer shall be transported exclusively in horizontal position. The manufacturer is not responsible for damage arising from the conditions of transport.

Before installation and operation one shall read the instructions and implement the precautions listed. Noncompliance with these precautions is grounds for releasing the manufacturer from warranty obligations.

2. Applications

Disinfection with UV radiation is a reliable, simple and inexpensive method of sterilization. The use of this method is possible whenever microbiological risk exists.

The applications of this method are, among many others:

- Potable water in private and municipal installations
- Potable and process water in restaurant and hotel business
- Process water in the production of medicines and cosmetics
- Water used in processing food
- Water in beverage production
- Water in swimming pools and fountains
- Control of green algae and bacterias in ponds
- And many more

The sterilizer uses special low pressure UV lamp that produces UV radiation of wavelength of 254 nm, which causes photochemical reaction damaging DNA of microorganisms and their disintegration.

Water flowing from the sterilizer is ready for immediate use. UV sterilization does not change the chemical makeup of water.

THERE IS NO POSSIBILITY OF OVERDOSING UV RADIATION
DURING WATER STERILIZATION IN THE CHAMBER.

MINIMAL FLOW OF WATER IS NOT REQUIRED.
INCREASED FLOW THROUGH THE STERILIZER LOWERS THE DOSAGE DELIVERED TO
MICROORGANISMS AND LOWERS EFFICIENCY OF DISINFECTION.

3. Technical description

- Sterilizer's chamber is made from stainless steel AISI 304 or AISI 316.
- Power supply is 220-240V + 8%, - 10%, 50-60 Hz.
- Electric shock protection by earth terminal.
- Power optical indicator in the electrical enclosure enables the indication of the working condition of the lamp.
- Sight glass muff enables the indication of the working condition of the UV lamp.
- Models D2, D4, D6, D8, D10 are equipped with a simple power supply.
- Models D6-S, D8-S, D12, D14 are equipped with an alarm system with a digital display that shows the remaining work time of the UV lamp, total work time of the device and the number of on/off switch cycles. In these models there is a possibility of connecting a solenoid valve or leading the alarm signal out.

4. Technical specification

TMA Białostoczek 26; gm. Zabłudów, 15-592 Białystok	WATER STERILIZERS- D series	Tel. 85 743 12 46; 85 687 14 50 www.tma.pl , www.tma.com.pl ; e-mail: biuro@tma.pl NIP: 542-000-84-13
	Models: D2; D4; D6; D6-S; D8	

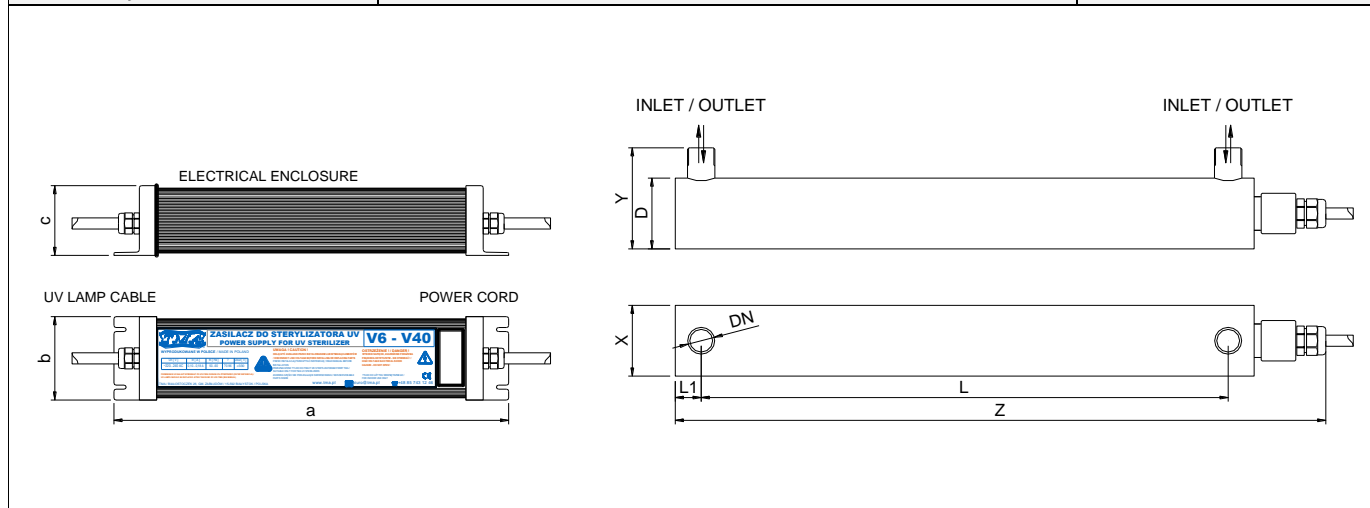

TECHNICAL SPECIFICATIONS:

Model	D2	D4	D6	D6-S	D8	
Power Supply	~220V-240V 50-60Hz	~220V-240V 50-60Hz	~220V-240V 50-60Hz	~220V-240V 50-60Hz	~220V-240V 50-60Hz	
Material	Stainless Steel	Stainless Steel	Stainless Steel	Stainless Steel	Stainless Steel	
Finish	Satin (Ra<0,8µm)	Satin (Ra<0,8µm)	Satin (Ra<0,8µm)	Satin (Ra<0,8µm)	Satin (Ra<0,8µm)	
Dimensions	X / Y / Z	70x100x404mm	70x100x650mm	130x240x660mm	130x240x660mm	70x100x960mm
	L	273mm	518mm	495mm	495mm	815mm
	DN / D	DN15 (R ½")	DN20 (R ¾")	DN25 (R 1")	DN25 (R 1")	DN25 (R 1")
Safety Class	IP66	IP66	IP66	IP66	IP66	
No. of UV Lamps x Nominal Power	1x 16W low pressure	1x 27W low pressure	1x 27W low pressure	1x 27W low pressure	1x 42W low pressure	
Life of UV Lamps	About 16 000 h	About 16 000 h	About 16 000 h	About 16 000 h	About 16 000 h	
Operating Temperature	0,5-45 °C	0,5-45 °C	0,5-45 °C	0,5-45 °C	0,5-45 °C	
Operating Pressure	10bar(1MPa)	10bar(1MPa)	10bar(1MPa)	10bar(1MPa)	10bar(1MPa)	
Nominal Power	17W	28W	28W	30W	43W	
Nominal Flow at transmittance T10=95%,dose 400J/m2	0.75m³/h	1.30m³/h	2.30m³/h	2.30m³/h	2.10m³/h	
Optical Power Indicator	Yes	Yes	Yes	Yes	Yes	
Drain Valve	No	No	Yes	Yes	Yes	
Orientation	From horizontal to vertical					

ELECTRICAL ENCLOSURE

Material	Aluminum/ABS	Aluminum/ABS	Aluminum/ABS	Plastic ABS	Aluminum/ABS
Safety Class	IP 41	IP 41	IP 41	IP65	IP 41
Dimensions	390x83x70mm	390x83x70mm	390x83x70mm	325x250x120mm	390x83x70mm
Audible UV Lamp Fault Alarm	No	No	No	No	No
Optical UV Lamp Fault Indicator	Yes	Yes	Yes	Yes	Yes
Optical Power Indicator	Yes	Yes	Yes	Yes	Yes
Total work time counter	No	No	No	Yes	No
Solenoid Valve Terminals	No	No	No	Yes	No
Terminals for Remote Alarm Indicator	No	No	No	Yes	No
UV Intensity Measurement System	On demand/ Additional charge	On demand/ Additional charge	On demand/ Additional charge	On demand/ Additional charge	On demand/ Additional charge
Weight with Enclosure	2.7kg	3.6kg	6.2kg	7.4kg	4.7kg

TMA Białostoczek 26; gm. Zabłudów, 15-592 Białystok	WATER STERILIZERS-D series	Tel. 85 743 12 46; 85 687 14 50 www.tma.pl ; www.tma.com.pl ; e-mail: biuro@tma.pl NIP: 542-000-84-13
	Models: D8-S; D10; D12; D14	

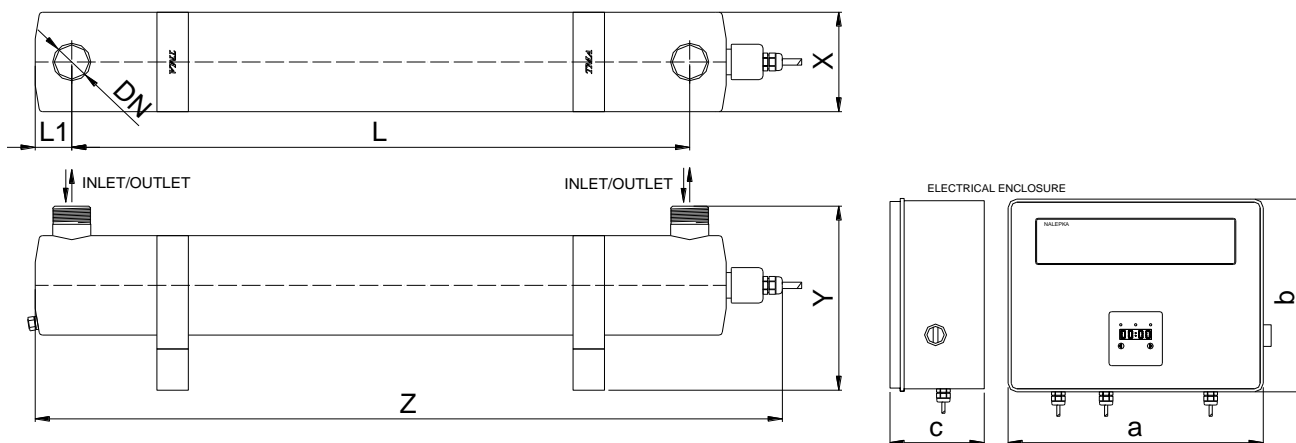

TECHNICAL SPECIFICATIONS:

Model	D8-S	D10	D12	D14
Power Supply	~220V-240V 50-60Hz	~220V-240V 50-60Hz	~220V-240V 50-60Hz	~220V-240V 50-60Hz
Material	Stainless Steel	Stainless Steel	Stainless Steel	Stainless Steel
Finish	Satin (Ra<0,8µm)	Satin (Ra<0,8µm)	Satin (Ra<0,8µm)	Satin (Ra<0,8µm)
Dimensions	X / Y / Z	70x100x960mm	130x2400x960mm	130x2400x960mm
	L	815mm	784mm	784mm
	DN / D	DN25 (R 1")	DN40(R1 1/2")	DN40 (R 1 1/2")
Safety Class	IP66	IP66	IP66	IP66
No. of UV Lamps x Nominal Power	1x 42W low pressure	1x 42W low pressure	1x 42W low pressure	1x 90W low pressure
Life of UV Lamps	About 16 000 h	About 16 000 h	About 16 000 h	About 16 000 h
Operating Temperature	0,5-45 °C	0,5-45 °C	0,5-45 °C	0,5-45 °C
Operating Pressure	10bar(1MPa)	10bar(1MPa)	10bar(1MPa)	10bar(1MPa)
Nominal Power	45W	43W	45W	90W
Nominal Flow at transmittance T10=95%,dose 400J/m2	2.10m ³ /h	3.90m ³ /h	3.90m ³ /h	7.40m ³ /h
Optical Power Indicator	Yes	Yes	Yes	Yes
Draining System	No	Yes	Yes	Yes
Orientation	From horizontal to vertical			

ELECTRICAL ENCLOSURE:

Material	Plastic ABS	Aluminum/ABS	Plastic ABS	Plastic ABS
Safety Class	IP65	IP 41	IP65	IP65
Dimensions	325x250x120mm	390x83x70mm	325x250x120mm	325x250x120mm
Audible UV Lamp Fault Alarm	Yes	Yes	Yes	Yes
Optical UV Lamp Fault Indicator	Yes	Yes	Yes	Yes
Optical Power Indicator	Yes	Yes	Yes	Yes
Total work time counter	Yes	No	Yes	Yes
Solenoid Valve Terminals	Yes	No	Yes	Yes
Terminals for Remote Alarm Indicator	Yes	No	Yes	Yes
UV Intensity Measurement System	On demand/ Additional charge	On demand/ Additional charge	On demand/ Additional charge	On demand/ Additional charge
Weight with Enclosure	5.9kg	8.6kg	9.8kg	10.2kg

TMA Company reserves the right to make design changes without notice.

ATTENTION!

- Minimal flow of water is not required for the devices to work.
- Increased flow through the sterilizer lowers the efficiency of disinfection.
- The device is comprised of stainless steel chamber and electrical enclosure.

5. Instructions for installation and operation

5.1. CORRECT ASSEMBLY OF THE CHAMBER

(graphic instructions at the end of the Manual)

	<p>Vertical</p>
	<p>Diagonal</p>
	<p>Horizontal</p>

ATTENTION!!!

The sterilizer shall be mounted in a way that prevents the creation of air pockets in the chamber: connectors shall be placed upwards in the horizontal position, water inlet on the bottom in the vertical and diagonal position. The UV lamp shall always be mounted in a horizontal or upward position.

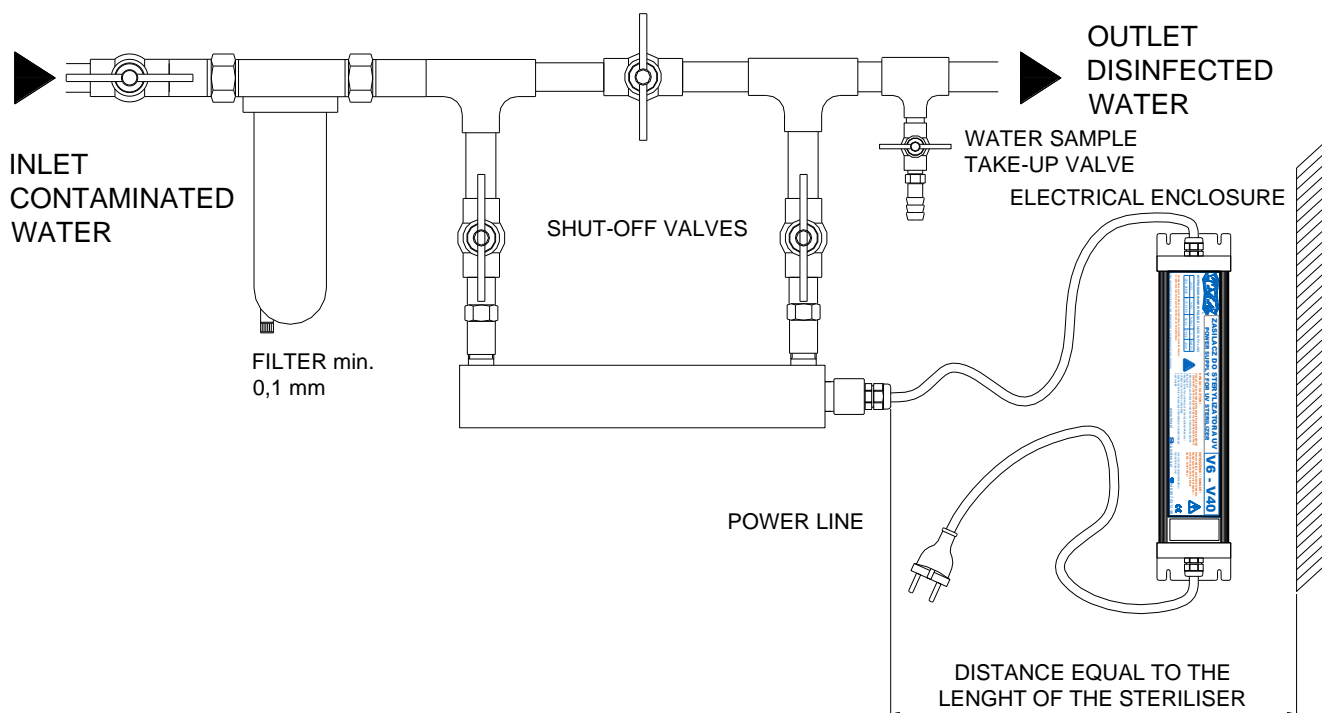

HORIZONTAL MOUNTING ARRANGEMENT OF THE UV STERILISER

- 1) Temperature range for installation is from 5 to 45°C.
- 2) Upstream of the intake install potable water filter. Minimum rating 0.1 mm, recommended 0.05 mm. The use of mesh screen filters is recommended (string wound filters may cause the multiplication of microorganisms).
- 3) Install manual cut-off valves, upstream of intake and downstream of outlet.
- 4) Close solenoid valves.
- 5) Connect the sterilizer chamber to water supply.
- 6) Mount the quartz sleeve into the chamber.
- 7) Place o-rings over the quartz sleeve. Next place the washer over the o-ring, screw the muff onto this assembly. Turn the muff to considerable resistance in order to tighten the seal. Use provided spanner to retighten the muff. Tightening the muff shall not break the sleeve. The use of any sealing materials for screwing the muff is prohibited.
- 8) Slowly open the solenoid valves and check the seal.
- 9) After checking the seal, place the UV lamp in the sleeve.
- 10) Push the socket on the UV lamp and slide it inside the quartz sleeve.
- 11) Push lamp hood on the muff.
- 12) Check if the strain relief cap is properly screwed.

5.2. CORRECT ASSEMBLY OF THE ELECTRICAL ENCLOSURE

- 1) Mount the electrical enclosure on the wall, at least 120 cm from the floor.
- 2) The electrical enclosure in D6-S, D8-S, D12, D14 shall be mounted with the provided holders – check the graphic assembly instructions on p.18.
- 3) Plug the unit into grounded outlet 220-230V, 50-60 Hz.
- 4) Sight glass muff enables indication of working condition of the lamp.
- 5) Replace the lamp according to the indications for each model /see the table on p.6-7/.

6. Connection of solenoid valve or leading the alarm signal out in D6-S, D8-S, D12, D14

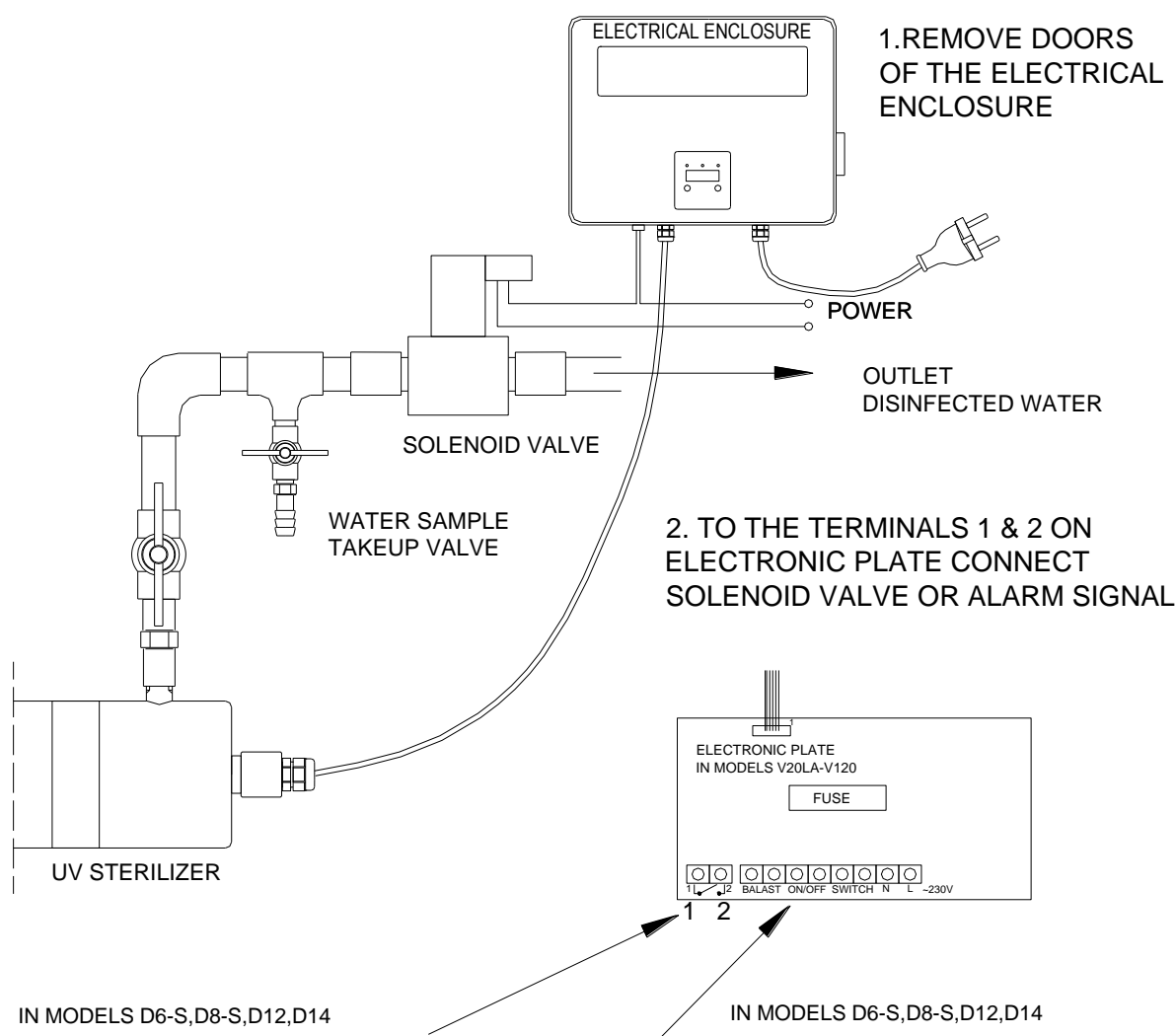

IN MODELS D6-S, D8-S, D12, D14

It is possible to connect solenoid valve type NZ (normally closed) max. 2a, or alarm signal to the terminals 1 & 2 /neutral/ on the electronic plate in electrical enclosure/.

- Contacts closed - sterilizer working properly
- Contacts open- UV lamp damage
- Alarm on
- Power cut off

IN MODELS D6-S, D8-S, D12, D14

After removing the bridge, it is possible to connect remote-controlled switch to the terminals ON/OFF /caution: **voltage 230V!**./

- Contacts closed - sterilizer on
- Contacts open- sterilizer off

ATTENTION! /APPLIES TO D6-S, D8-S, D12, D14/

Any fault or burnout of the lamp shall cause intermittent light and audible signal on the display of the alarm system /see pt. 14/

In the case of installing solenoid shut-off valve (terminals 1 & 2) upstream /or downstream/ of the sterilizer, tripping alarm or power interruption causes immediate shutting off of fluid flow to the chamber of the sterilizer /diagram 1a/. Terminals 1 & 2 have internal connection broken in case of alarm tripping and as such are neutral. Power to solenoid shut-off valve shall be connected through terminals 1 & 2.

Solenoid shut-off valve serves the purpose of preventing unsterilized fluid entering the installation downstream of the sterilizer in the case of power interruption or lamp failure.

6.1. CONNECTION OF SOLENOID VALVE

Connect solenoid valve type NZ (normally closed) max. 2A to the terminals 1 & 2 /neutral/ on the electronic plate in electrical enclosure.

Contacts 1 & 2 start working after a preset time delay of 2-3 min – it is a time necessary for the device to become fully operational. During this time the contacts remain open. After 2-3 min, the device works according to these rules:

• CONTACTS 1-2 CLOSED	- sterilizer working properly
• CONTACTS 1-2 OPEN	- UV lamp damage - Alarm on - power cut-off

6.2. LEADING OUT THE ALARM SIGNAL

Connect alarm signal wires to the terminals 1 & 2 on electronic plate /neutral/.

Contacts 1 & 2 start working after a set time delay of 2-3 min – it is a time necessary for the device to become fully operational. During this time the contacts remain open. After 2-3 min, the device works according to these rules:

• CONTACTS 1-2 CLOSED	- sterilizer working properly
• CONTACTS 1-2 OPEN	- UV lamp damage - Alarm on - power cut-off

6.3. REMOTE-CONTROLLED ON/OFF SWITCH

/CAUTION: VOLTAGE 230V/ BEFORE ASSEMBLY DISCONNECT THE POWER SUPPLY

After removing the bridge, it is possible to connect remote-controlled switch to the ON/OFF terminals on the electronic plate.

• ON/OFF TERMINALS CLOSED	- sterilizer on
• ON/OFF TERMINALS OPEN	- sterilizer off

7. Maintenance

- UV radiation damages skin and eyesight. It is forbidden to directly observe UV lamp during operation.
- There is no need for minimal flow through the device as it is designed in such a way that there may be no flow through the chamber with no damage to the sterilizer.
- UV sterilizer should run constantly - its long-term shutdown may cause bacterial or viral reinfection in the installation, which is very difficult to remove.
- It is recommended to install a filter (e.g. mesh screen) upstream of the sterilizer's input (using string wound filters may cause bacterial multiplication).
- Water not fit for consumption may require treatment, i.e. de-ironing, softening or filtering. If in doubt, please contact your dealer.

- f) In case of high turbidity and waste water, the choice of equipment and efficiency should be made by the dealer or producer.
- g) Sterilizers must be sized for the **maximum momentary flow of water** (matching them to the daily flows may result in incomplete disinfection).
- h) Avoid frequent turning on and off the equipment. One on-off cycle lowers the UV lamp life by about 10-20 hours.
- i) Sterilizers should not be installed in such a way that their work depended on other devices, e.g. pumps, pressure tanks, filters.
- j) Flow rate through the device can be increased, however, this lowers the delivered dosage and lowers the efficiency of disinfection.
- k) It is recommended to check cleanness of the quartz sleeve whenever the UV lamp is replaced.
- l) Cleaning the quartz sleeve is necessary anytime any deposit is noticed on its surface. Neglecting this may decrease the efficiency of disinfection.
- m) **Inlet and outlet valves shall be opened slowly** to prevent the rush of fluid hitting and damaging the quartz sleeve.
- n) The device needs about 2 minutes to reach full efficiency at water temperature of about 12-16°C. If the water is at temperature 5-12°C, it might take about 3-5 minutes.
- o) If the sterilizer is left idle for longer period of time or it can freeze, we recommend that the water be drained from the chamber. The chamber is provided with a drain valve.
- p) Bioassay samples shall be collected into sterile opaque containers.







8. Description of indicators in electrical enclosures

Illuminated indicators in the electrical enclosure indicate that the device operates correctly or that there are problems that can be solved in the following way:

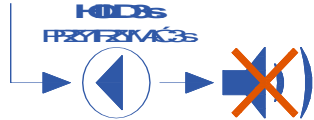
8.1. IN D2, D4, D6, D8, D10

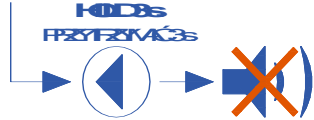
UV lamp work indicator <i>sight glass muff</i>	Power supply <i>Green light</i>	Problem	Action
ON	ON	No fault	-
OFF	ON	Old or faulty UV lamp.	Shut off power supply. Replace UV lamp.
OFF	OFF	No power connected.	Check power.
OFF/VISIBLE ORANGE LIGHT	ON	UV lamp damaged or depressurized.	Shut off power supply. Replace UV lamp.

8.2. IN D6-S, D8-S, D12, D14

Display indications	Cause	Solution
 <ul style="list-style-type: none"> - Blinking digit 7 on the display. - An intermittent sound signal. 	<ul style="list-style-type: none"> - 7 days left to the end of UV lamp life. - Change UV lamp in 7 days. 	 <p>Press and hold the left button for more than 3 seconds to silence the sound alarm.</p>
 <ul style="list-style-type: none"> - Blinking number 0 on the display. - An intermittent sound signal. 	<ul style="list-style-type: none"> - UV lamp reached the end of its life. 	 <p>Press and hold the left button for more than 3 seconds to silence the sound alarm (repeat max 2 times)</p>
 <ul style="list-style-type: none"> - Blinking numbers 8 on the display. - Blinking 3 LEDs over the display. - Continuous sound signal. 	<ul style="list-style-type: none"> - UV lamp is damaged or reached the end of its life time. 	<p>Change UV lamp.</p>
 <ul style="list-style-type: none"> - The display shows weird signs. - 2 or 3 LEDs light up over the display. 	<ul style="list-style-type: none"> - Possible fault of the display or the microprocessor. 	<p>Contact the dealer.</p>
 <ul style="list-style-type: none"> - No indication on the display. - No indication on LED above display. - No audible alarm. 	<ul style="list-style-type: none"> - No power connected at the input of the electrical enclosure. 	<ul style="list-style-type: none"> - Check power. - Check the fuse in the alarm system.
 <ul style="list-style-type: none"> -No indication on the display or -blinking digits or -alarm signal is on. 	<ul style="list-style-type: none"> -Loosened 6 wire tape connecting the display with the power supply. 	<ul style="list-style-type: none"> - Shut off power supply. - Disconnect the tape. - Reconnect the tape.

9. D series sterilizers service

9.1. REPLACEMENT OF UV LAMP

(graphic instructions at the end of the Manual)

- a) Disconnect the power supply,
- b) Allow for the lamp to cool down from operating temperature,

Replacement of the UV lamp does not require the stop of fluid flow through the chamber

- c) Loosen the strain relief grip on cable,
- d) Carefully take off the lamp hood with the UV lamp from the quartz sleeve,

DO NOT UNSREW THE MUFF!

- e) Remove the sockets from the connectors of the UV Lamp,
- f) Remove old UV lamp from the quartz sleeve,
- g) Carefully place the new UV lamp in the sleeve,
- h) Reverse the remaining steps.

9.2. RESETTING THE COUNTER IN THE ALARM SYSTEM / in D6-S, D8-S, D12, D14 /

The counter in the alarm system needs to be reset each time the UV lamp is replaced.

- a) Disconnect from power supply.
- b) Replace the UV lamp – see pt. 9.1. REPLACEMENT OF THE UV LAMP.
- c) Connect device to power supply (power switch should be turned off).
- d) Press and hold the right button on the display for about 10 s.

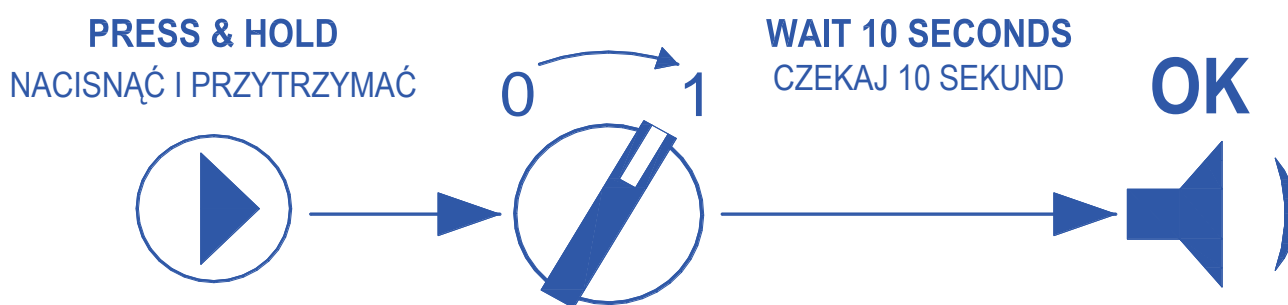

- e) Turn on the device while still holding the right button on the display.

To reset the counter the UV lamp must be connected and fully functional.

- f) A short audible signal will confirm the resetting of the counter.

9.3. REPLACEMENT AND CLEANING OF THE QUARTZ SLEEVE /FRAGILE AND BRITTLE/

(graphic instructions at the end of the manual)

- a) Disconnect the power supply,
- b) Cut off the liquid flow through the chamber,
- c) Remove the water from the chamber,
- d) Allow for the lamp to cool down from operating temperature,
- e) Remove the UV lamp from the sleeve / see pt. 9.1 /.
- f) Unscrew the steel muff using the special spanner,
- g) Take off the washer and o-ring from the quartz sleeve,
- h) Pull out the quartz sleeve from the sterilizer chamber,
- i) Every time the UV lamp is replaced, if it is necessary to clean the quartz sleeve, use common glass cleaners and dry thoroughly the interior of the sleeve.
- j) **A new o-ring must be used each time the UV lamp is replaced.**
- k) Place the sleeve in the chamber of the sterilizer, put on a new o-ring and a washer,
- l) Hand tighten the muff with the new o-ring. Use provided spanner to retighten the muff,
- m) Open the shut-off valves slowly to pressurize the chamber and watch for leaks at the o-ring,

9.4. TROUBLESHOOTING

Problem	Cause	Action
Burned out UV Lamp.	End of lamp life caused by number of working hours or number of on-off cycles.	Disconnect the device from the power supply. Replace the UV lamp.
Burned out UV Lamp. Water inside quartz sleeve.	Muff not tightened sufficiently. Worn out o-ring.	Disconnect the device from the power supply. Take quartz sleeve out, dry interior, change o-ring, and assemble back. Tighten muff. Replace the UV lamp.
UV lamp electrode glows red or yellow.	Damaged or depressurized UV lamp.	Disconnect the device from the power supply. Replace the UV lamp.

10. Spare parts list

	D SERIES UV WATER STERILIZER		NO.
	TITLE	D2- D14 – SPARE PARTS LIST	3

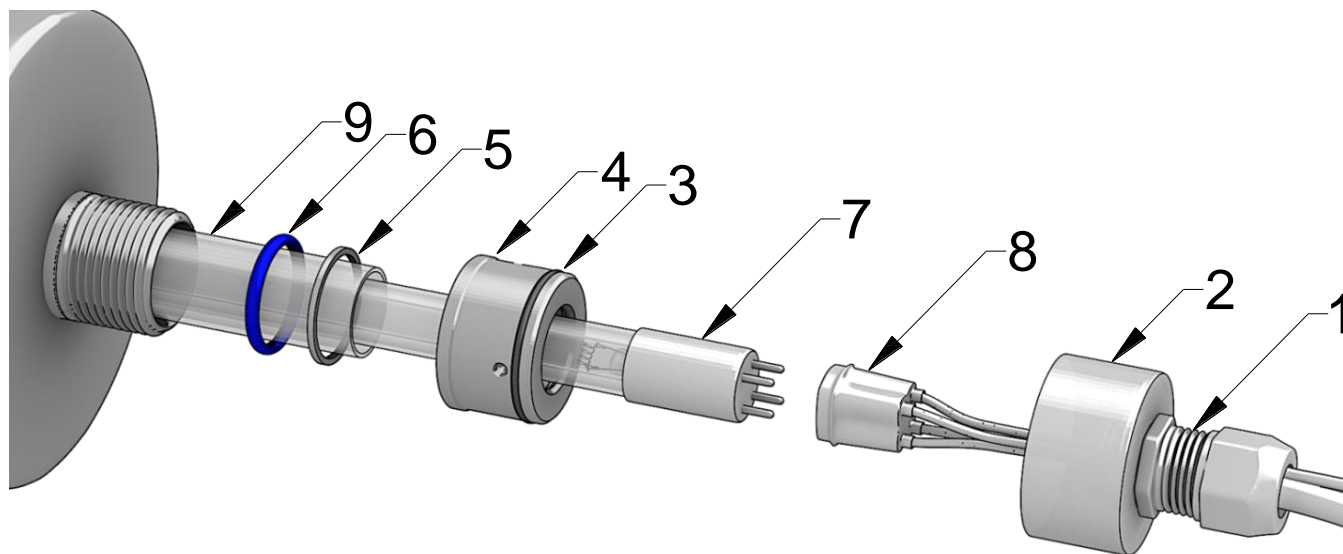

No	PART	No. of	D2	D4	D6	D6-S	D8	D8-S	D10	D12	D14
1	STRAIN RELIEF	1	05.01	05.01	05.01	05.01	05.01	05.01	05.01	05.01	05.01
2	LAMP HOOD	1	02.02.01	02.02.01	02.02.01	02.02.01	02.02.01	02.02.01	02.02.01	02.02.01	02.02.01
3	MUFF O-RING	1	02.03.01	02.03.01	02.03.01	02.03.01	02.03.01	02.03.01	02.03.01	02.03.01	02.03.01
4	MUFF	1	03.04	03.04	03.04	03.04	03.04	03.04	03.04	03.04	03.04
5	WASHER	1	02.05	02.05	02.05	02.05	02.05	02.05	02.05	02.05	02.05
6	O-RING	1	02.06	02.06	02.06	02.06	02.06	02.06	02.06	02.06	02.06
7	UV LAMP	1	17.07	18.07	18.07	18.07	19.07	19.07	19.07	19.07	20.07
8	SOCKET	1	-	-	-	06.08	-	06.08	-	06.08	06.08
9	QUARTZ SLEEVE	1	06.09	08.09	08.09	08.09	10.09	10.09	10.09	10.09	10.09

11. Graphic assembly instructions

11.1. ASSEMBLY OF THE STERILIZERS WITH BRACKETS – D6, D6-S, D10, D12, D14

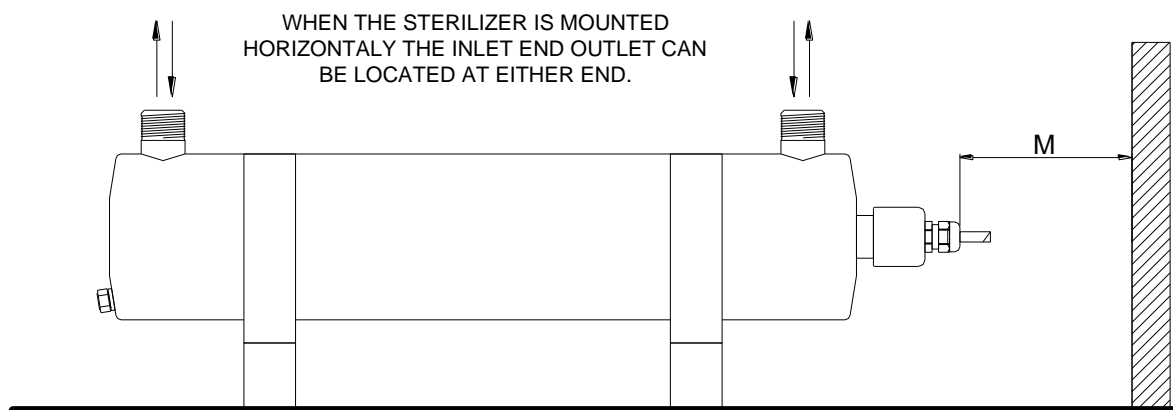

1. LOOSEN THE SCREW AND ADJUST THE POSITION OF THE CHAMBER FOR THE INSTALLATION NEEDS
2. TIGHTEN THE SCREWS.

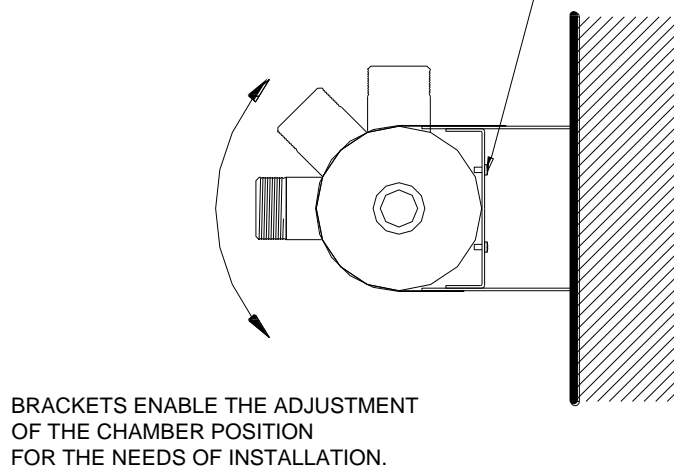

WHEN THE STERILIZER IS MOUNTED VERTICALLY OR AT ANY OTHER ANGLE, THE OUTLET HAS TO BE LOCATED AT THE TOP OF CHAMBER

M - DISTANCE NEED FOR REPLACMENT OF THE UV LAMP

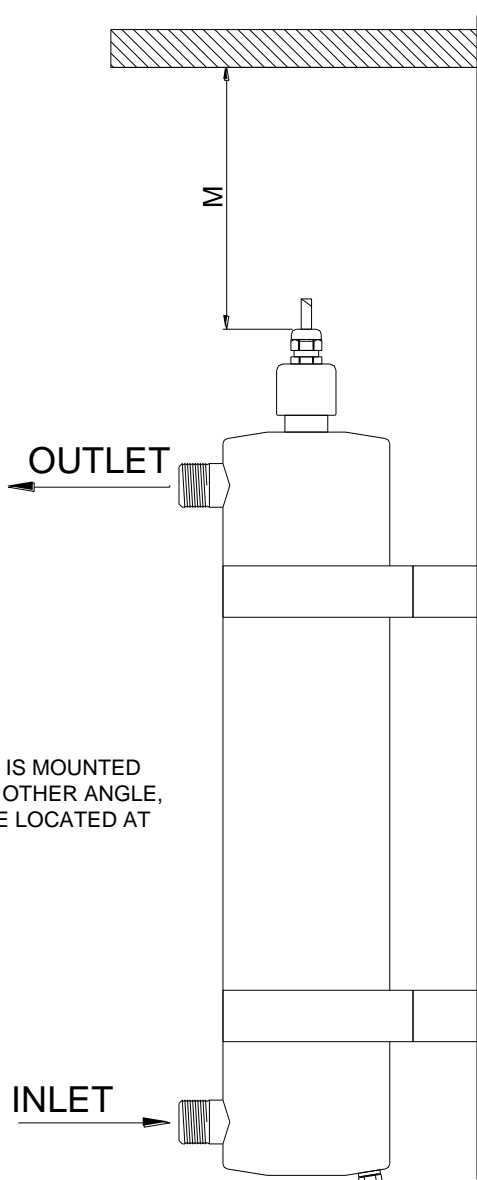

11.2. ASSEMBLY OF THE ELECTRICAL ENCLOSURES IN D6-S, D8-S, D12, D14

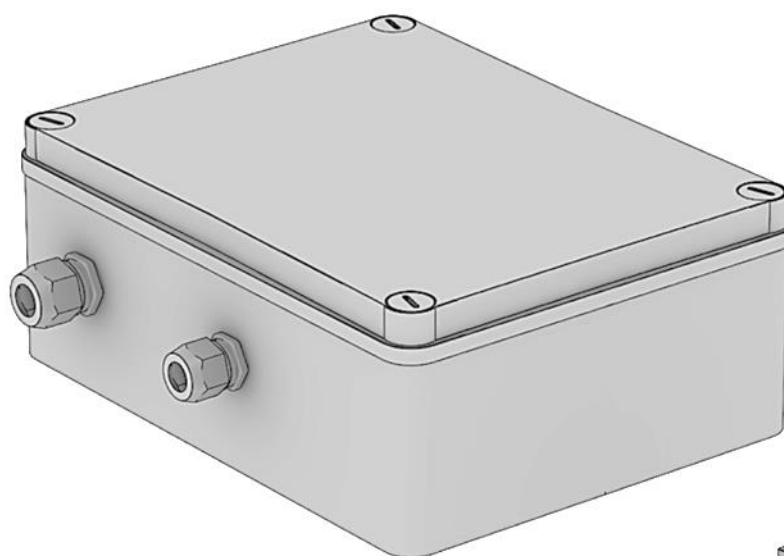

1

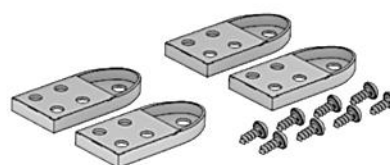

Option I

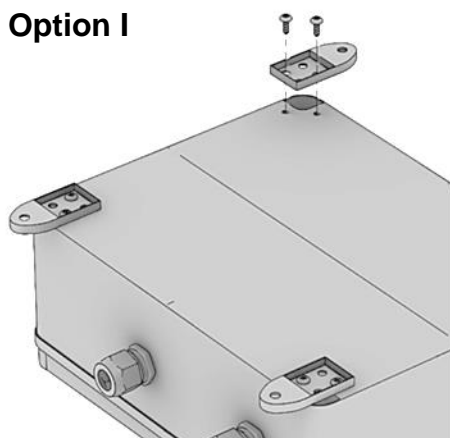

Option II

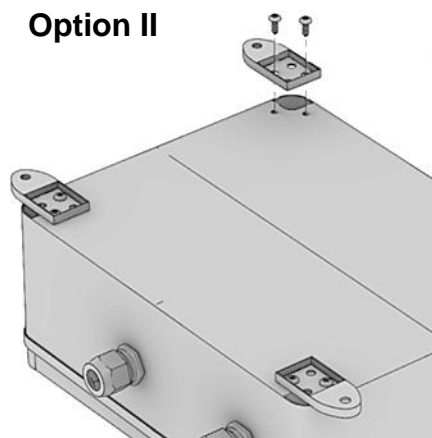

2

Option I

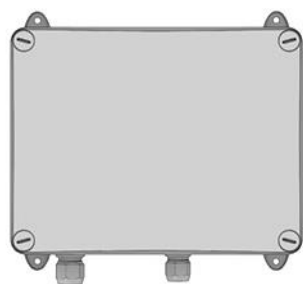

Option II

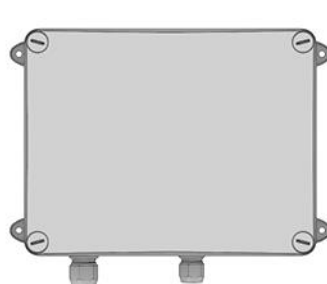

3

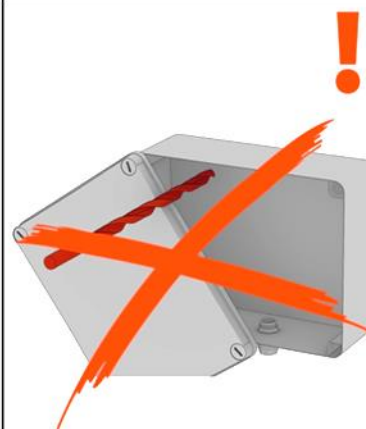

11.3. ASSEMBLY OF D2, D4, D8, D8-S

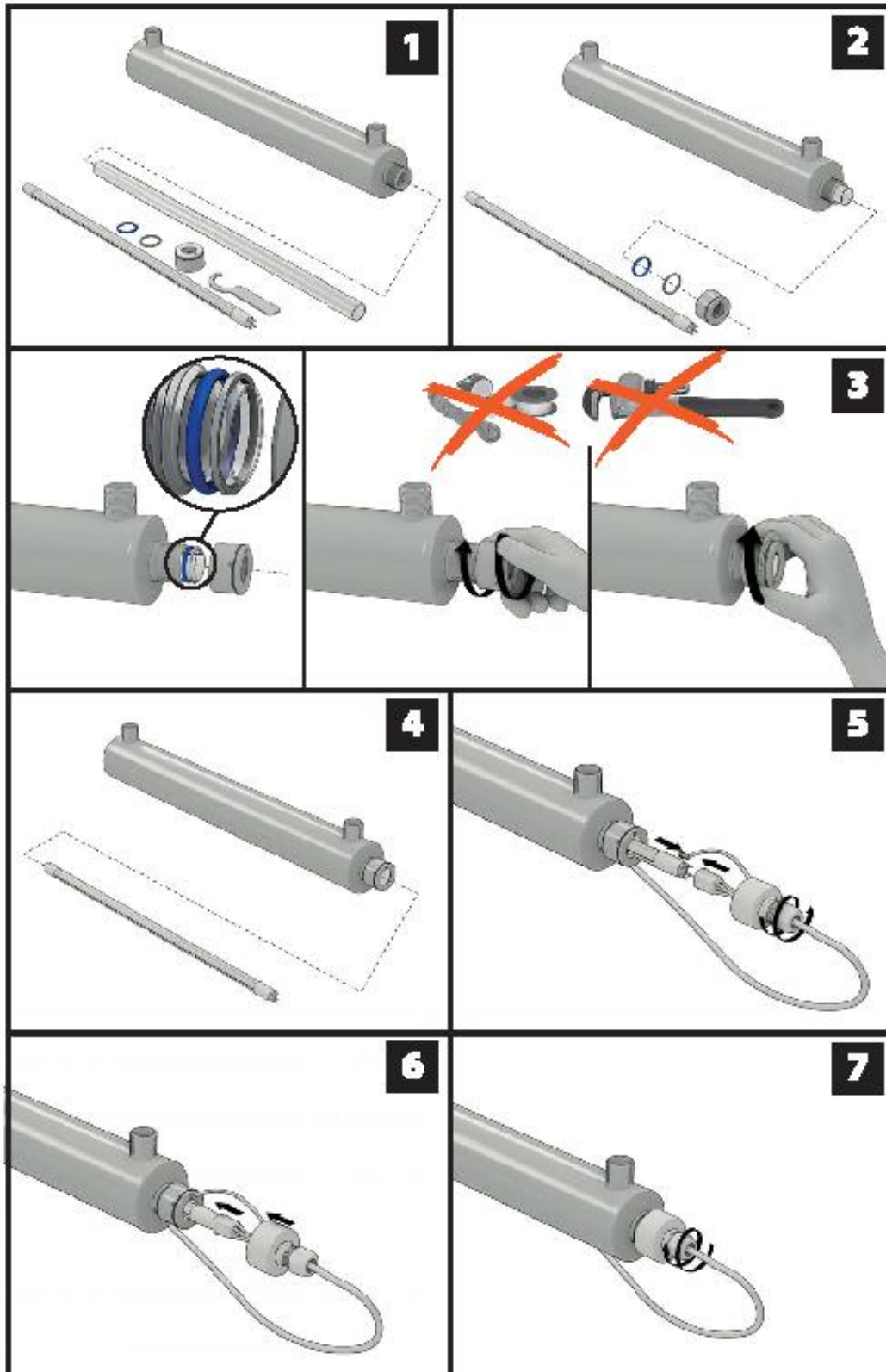

11.4. ASSEMBLY OF D6, D6-S, D10, D12, D14

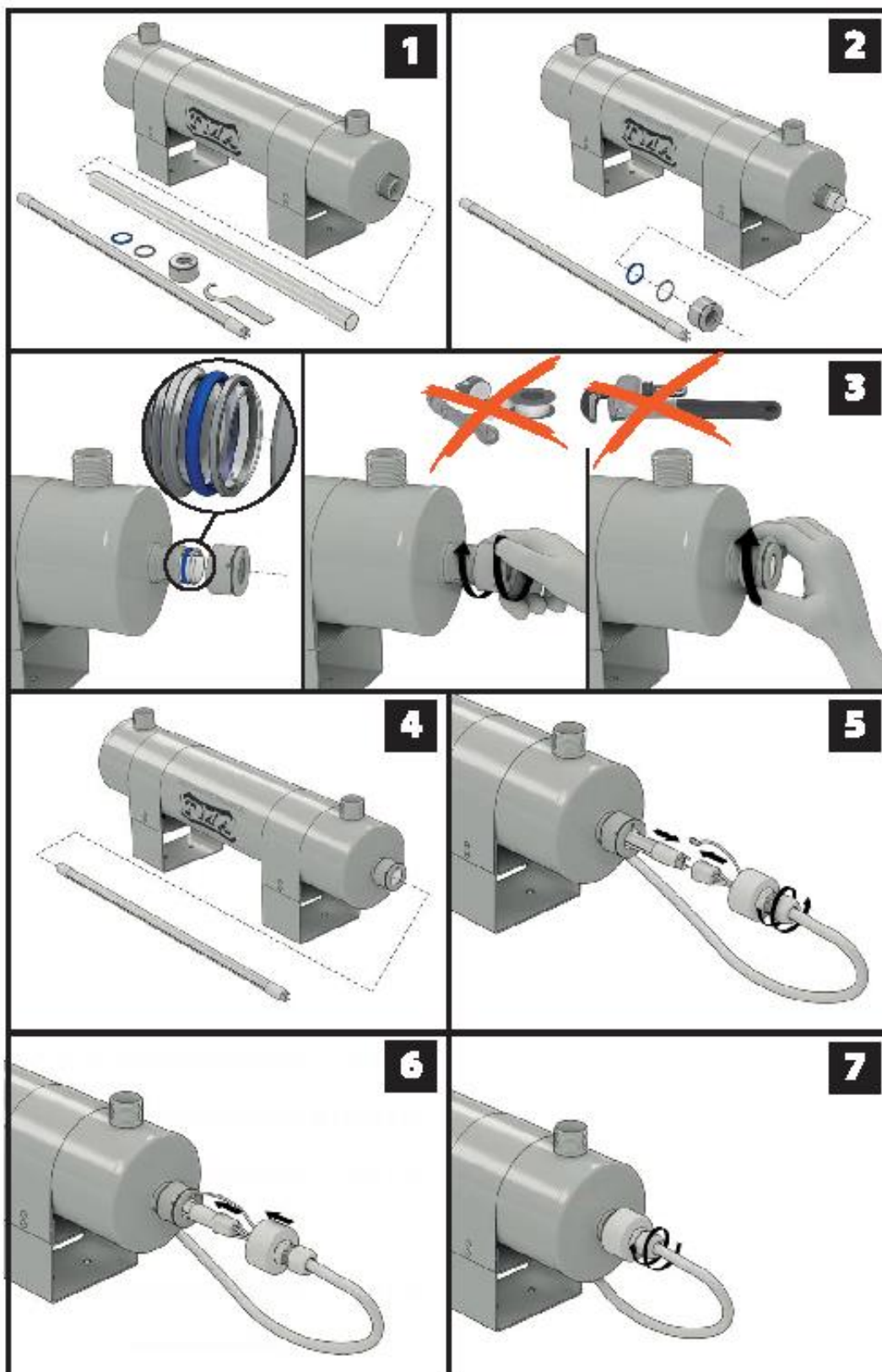

12. Declaration of conformity

Białostoczek, 2022-04-01

Deklaracja zgodności TMA/01/04/2022

Declaration of conformity

1. Producent wyrobu /

The manufactured of the product: TMA

Białostoczek 26, gm. Zabłudów
15-592 Białystok
Polska / Poland

Zakład produkcyjny:

TMA
Białostoczek 26, gm. Zabłudów
15-592 Białystok
Polska / Poland

Deklaruje, że produkty / Hereby declares that the sterilisers:

2. Nazwa wyrobu / Models: Sterylizator / Steriliser

SERIA/SERIES V/ SERIA D
SERIA/SERIES AM / TM / AP-POOL
SERIA/SERIES AMX / AP-POOL X / AP-POOL-N
CZUJNIK UV UVC-02/UV METER UVC-02

3. Klasyfikacja wyrobu / Product classification:

SWW 0719-149, PKWiU28.29.12.0 (29.24.12-30.20)

4. Przeznaczenie i zakres stosowania wyrobu / The scope of use:

Dezynfekcja promieniami UV wody pitnej, grzewczej,
basenowej, wód technologicznych, emulsji chłodzących,
ścieków oczyszczonych
/ UV disinfection of notable, heating, pool and technological
waters, cooling emulsions, treated waste water

5. Dokumenty odniesienia / Reference documents:

2014/35/UE / w miejsce / it replaces 2006/95/WE/
Dyrektywa niskonapięciowa / Low Voltage Directive
2014/30/UE /w miejsce 2004/108/WE/
Kompatybilność elektromagnetyczna /
Electromagnetic Compatibility Directive
2014/68/UE /w miejsce / it replaces 97/23/WE/
Urządzenia ciśnieniowe / Pressure Equipment Directive
EN 605529 Stopnie ochrony zapewniane przez obudowy /
Degrees of casings' protection.

zostały zaprojektowane zgodnie z zasadami dobrej praktyki inżynierskiej.

/ are designed in accordance with good engineering practice./

Deklaruję z pełną odpowiedzialnością, że wyroby z partii określonej w pkt.2 są zgodne z dokumentami odniesienia wymienionymi w pkt 5.

/I hereby declare with full responsibility that the products from the lot determined in the declaration comply with the reference documents defined in p. 5./

Partia wyrobów objęta deklaracją./The lot determined in the declaration.: 24000 - 28000



15-592 Białystok
Białostoczek 26
gm. Zabłudów
NIP 542-000-84-13, Regon 002333645
tel. +48 85 7431246, e-mail: biuro@tma.pl

Mgr inż. Tomasz Adamowicz

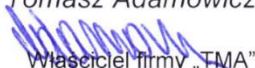

Właściciel firmy „TMA”
/The owner of the company/

13. Hygienic certificate



PRODUKT Z ATESTEM

NARODOWY INSTYTUT ZDROWIA PUBLICZNEGO PZH
– Państwowy Instytut Badawczy
NATIONAL INSTITUTE OF PUBLIC HEALTH NIH – National Research Institute
ZAKŁAD BEZPIECZEŃSTWA ZDROWOTNEGO ŚRODOWISKA
DEPARTMENT OF ENVIRONMENTAL HEALTH AND SAFETY

ATEST HIGIENICZNY**B-BK-60210-0702/21**

HYGIENIC CERTIFICATE

ORYGINAŁ

NATIONAL INSTITUTE OF PUBLIC HEALTH NIH – NATIONAL RESEARCH INSTITUTEWyrób / product: **Sterylizatory UV seria D**

Zawierający / containing: komorę ze stali kwasoodpornej 304L/316L, układ sterowniczy, promienniki UV-C w osłonie kwarcowej, uszczelnienie z EPDM

Przeznaczony do / destined: dezynfekcji wody przeznaczonej do spożycia przez ludzi, wody do użytku gospodarczego, wód technologicznych, wód basenowych oraz innych cieczy

Wymieniony wyżej produkt odpowiada wymaganiom higienicznym przy spełnieniu następujących warunków / the above-named product is acceptable according to hygienic criteria with the following conditions:

Urządzenia można stosować do wód klarownych i bezbarwnych. Typ urządzenia należy dobrać w zależności od jakości wody w danym wodociągu i wymogów użytkownika. Do urządzenia należy dołączyć instrukcję użytkowania zawierającą informacje o zalecanej szybkości przepływu wody. Na stosowanie w wodociągach publicznych lamp UV do dezynfekcji wody przeznaczonej do spożycia, należy każdorazowo uzyskać zgodę terenowo właściwego Państwowego Powiatowego Inspektora Sanitarnego.

Atest nie dotyczy parametrów technicznych wyrobów/The hygienic certificate does not apply to technical parameters of the products.

Wytwórca / producer:

TMA Tomasz Adamowicz
15-592 Białystok

Białostoczek 26, gm. Zabłudów

Niniejszy dokument wydano na wniosek / this certificate issued for:

TMA Tomasz Adamowicz
15-592 Białystok

Białostoczek 26, gm. Zabłudów

Atest może być zmieniony lub unieważniony po przedstawieniu stosownych dowodów przez którąkolwiek stronę. Niniejszy atest traci ważność po 2024.08.10 lub w przypadku zmian w recepturze albo w technologii wytwarzania wyrobu.

The certificate may be corrected or cancelled after appropriate motivation. The certificate loses its validity after 2024.08.10 or in the case of changes in composition or in technology of production.

Data wydania atestu higienicznego: 10 sierpnia 2021

The date of issue of the certificate: 10th August 2021

Kierownik
Zakładu Bezpieczeństwa Zdrowotnego
Środowiska

z g. Jolanta Solecka, prof. NIZP PZH - PIB

Kontakt w sprawie niniejszego atestu higienicznego / To contact regarding this hygienic certificate
Zakład Bezpieczeństwa Zdrowotnego Środowiska NIZP PZH - PIB / Department of Environmental Health and Safety NIPH NIH - NRI
00-791 Warszawa, ul. Chocimska 24 / 00-791 Warsaw, Chocimska 24, Poland
e-mail: sekretariat-bk@pzh.gov.pl tel. +48 22 54-21-354, +48 22 54-21-349

14. Shipping

Devices should be shipped in packaging capable of withstanding rough handling /preferably in the original packaging/. The quartz sleeve and UV lamp should be disassembled and packed sufficiently to prevent their breakage.

15. Warranty

1. UV sterilizers are used to sterilize water/liquids from a known source.
2. The manufacturer, TMA company, warrants faultless operation of the devices covered by this Warranty.
3. The conditions for warranty claims during the warranty period are:
 - Possession of a proof of purchase (invoice, receipt).
 - Assembly and exploitation of the device in accordance with the Manual (provided with the device).
4. All defects of the product determined at any time during this Warranty shall be repaired at no additional charge within 14 days from the date of delivery of the defective product to the manufacturer, based on this filled Warranty. In exceptional situations, this period can be extended to 21 days.
5. Defective Products shall be delivered to the manufacturer in a **complete** state and packed sufficiently to withstand the shipping conditions. The manufacturer shall not be liable for any damage of the products during transport.
6. During the Warranty period, the manufacturer repairs or replaces the parts of the devices, in such order, with no additional cost for the user. All the parts/elements/components replaced during the Warranty period become the property of the manufacturer.
7. In case of unfounded claims, the claimant shall be charged with the cost of all the provided services, e.g. shipment cost.
8. The assembly and exploitation of the device can be performed after the user's familiarization with the Manual provided with the device.
9. Manufacturer warrants that the product shall meet all specifications of performance as stated in the Manual for the period of:
 - 36 months from the date of purchase covering the stainless steel chamber,
 - 24 months from the date of purchase covering all electrical parts of the sterilizer.
10. The chamber is covered by Warranty for 36 months, as long as it is used for substance disinfection in accordance with the steel corrosion resistance list, according to EN 10088-1 norm.
11. The use of the product not in accordance with the EN 10088-1 norm shall result in the loss of Warranty for the chamber and cannot be grounds for any claims in case of chamber damage.
12. The water flowing through the device cannot contain sulphur, solid substances that can be filtered or iron over 0.3 mg/dm³.
13. No warranty is given for the chambers made from AISI 304 stainless steel in the case of:
 - Chlorinated water with chlorine content greater than 0.3 mg/dm³, e.g. in swimming pools
 - The contents of chlorides greater than 200 mg/dm³
 - pH outside the range 6.5-9.5
 - application for brine water above 250 mg/dm³ NaCl
 - application to demineralized and distilled water
14. No warranty is given for the chambers made from AISI 316 stainless steel in the case of:
 - Chlorinated water with chlorine content greater than 1,0 mg/dm³

- The contents of chlorides greater than 450 mg/dm³
 - pH outside the range 6.5-9.5
 - Application for brine water above 800 mg/dm³ NaCl
15. The purchaser shall have the right to have the product replaced if:
- It is determined that there is a manufacturing defect which is irreparable; or
 - During the Warranty period there is a need of 4 repairs and even after these the exploitation of the product according to the instructions is impossible.
16. The term 'repair' does not cover all the actions stipulated in the Manual (i.e. routine maintenance) which are to be performed by the user.
17. The Warranty does not cover:
- Damage caused by inadequate storage of the products by the purchaser,
 - Damage caused by faulty assembly or exploitation of the sterilizer,
 - Damage caused by misuse, neglect, installation or application not in accordance with the manufacturer's recommendations/Manual,
 - Damage caused by the use of unoriginal spare parts,
 - Damage caused by unpredictable natural phenomena, i.e. floods, frost, storms, hurricanes or earthquakes,
 - UV burner,
 - Quartz casing,
 - Elements subject to normal wear and tear, such as o-rings, gaskets, electrical cables etc.
18. The manufacturer shall be relieved from any liability in the following situations:
- If, during the warranty period, the device is repaired or replaced by parties not authorized by the manufacturer – the TMA company.
 - If the device is powered by voltage different than specified in the Manual.
 - If unoriginal spare parts are used.
 - If the device is used for purposes not in accordance with the recommendations in the Manual, data sheet and Warranty.
 - In cases of damage caused by unpredictable natural phenomena, i.e. floods, frost, storms, hurricanes or earthquakes.
 - If the buyer does not possess any proof of payment or valid warranty signed by the manufacturer/dealer.
 - If the device does not have any manufacturer's labels/markings.
19. This Warranty is limited to the obligations stated above and does not cover the effects of damage caused by break-downs of the appliance or disinfection efficiency.
20. The manufacturer shall not be liable for any financial loss or other civil law consequences resulting from any defects of the device. It specifically relates to: loss of turnover, profit, possible benefits, damage of products and media.
21. Warranty claims may relate only to the replacement or repair of defective parts of UV sterilizers.

THE WARRANTY SHALL NOT COVER DEVICES NOT BEARING THE TMA LOGO.

Warranty and post warranty repairs		
Date of acceptance	Type of failure and repair procedure	Repair end date